



**unit shown with optional lighting and side rails*

For wheelchairs, bicycles and goods deliveries

MPG motorized swing gates are the optimum barrier solution when a large passage opening is required at indoor or outdoor access points. It can be free-standing or used in combination with a Magnetic MPT turnstile. The swing gate has an opening angle of 90° in both directions and can be controlled by most access control systems. As an option, the swing gate can be enhanced with a single- or double-sided induction loop that reliably detects the presence of bicycles and wheelchairs. The induction loops are cleverly incorporated into the vertical side rails.

The swing gate is energy-efficient, maintenance-free and quiet thanks to its MHTM™ drive technology. Low impact force and sensitive contact detection ensures user safety and compliance with strict industry standards. With a variety of material options, interlocks and supplementary attachments, MPG swing gates can be individually outfitted for the desired purpose.



For wheelchairs, bicycles and baggage
MPG swing gates are the optimum solution when large opening widths are necessary. A wide variety of options are available for access control.



Innovative drive technology
The MHTM™ drive unit is maintenance-free, energy-efficient, and has an exceptional soft-start action.

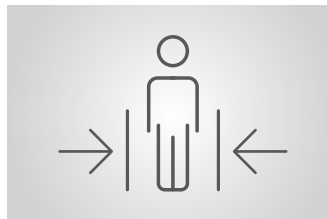

Maximum safety
Low impact force and high sensitivity contact detection offer optimum protection for persons, bicycles, carts and wheelchairs.



Easy access to components
All the components necessary for operation are contained in the main header beam, simplifying assembly, setup and maintenance.









MPG

Wheelchair-Accessible Swing Gate

- > Fully-motorized operation
- > Controlled access for cyclists and wheelchair users
- > Sensitive impact detection for maximum safety
- > Induction loop sensor for detection of bicycles and wheelchairs (optional)
- > Low electricity consumption thanks to maintenance-free MHTM™ drive
- > Meets European safety standards, e.g. EN 13241



Technical data	MPG 162	MPG 172
Installation	in combination with turnstile system	free-standing
Drive technology	MHTM™	MHTM™
Voltage	110 – 240 VAC, 50/60 Hz	110 – 240 VAC, 50/60 Hz
Power consumption	approx. 50 W	approx. 50 W
Duty cycle	100 %	100 %
Opening/closing times	approx. 3 s	approx. 3 s
Passage width	42.8 in	42.1 in
Enclosure rating	IP 43	IP 43
Dimensions (L x W x H)	57.1 x 19.7 x 88 in	63.9 x 19.7 x 88 in
Weight	approx. 485 lb	approx. 550 lb
Temperature range	-13 to +122° F	-13 to +122° F

Options		Potential applications
Material	Galvanized steel, powder-coated steel in standard colors, powder-coated steel in special colors, stainless steel 316	    
Sensors	Single-sided/double-sided induction loop to detect wheelchairs and bicycles	
Reaction to power failure	Free access or auto-locking on power failure	
Attachments	Overhead illumination, gate end display	
		Standard colors
		  
		RAL 7042 RAL 7016 RAL 6005

Dimensional drawings

MPG 162
View from inside

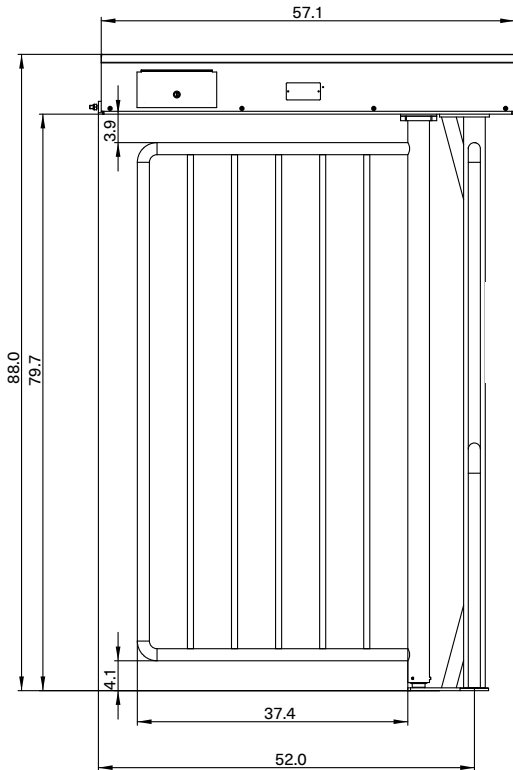

MPG 172
View from inside

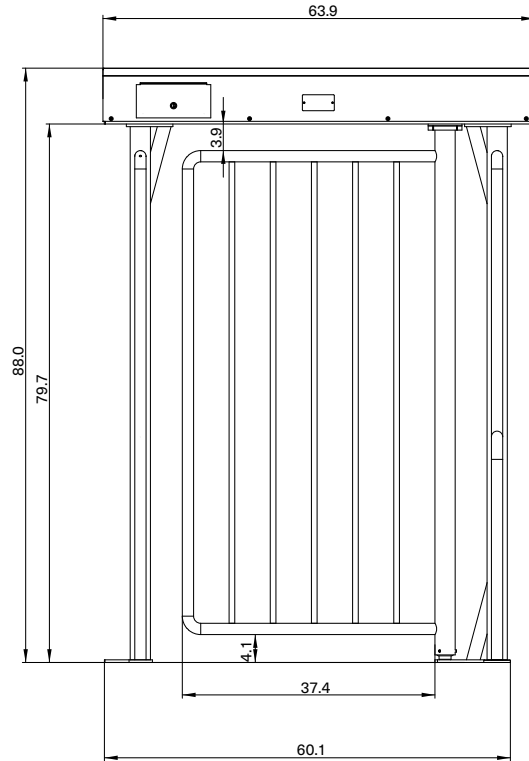

MPG 162 und MPG 172
View from the side

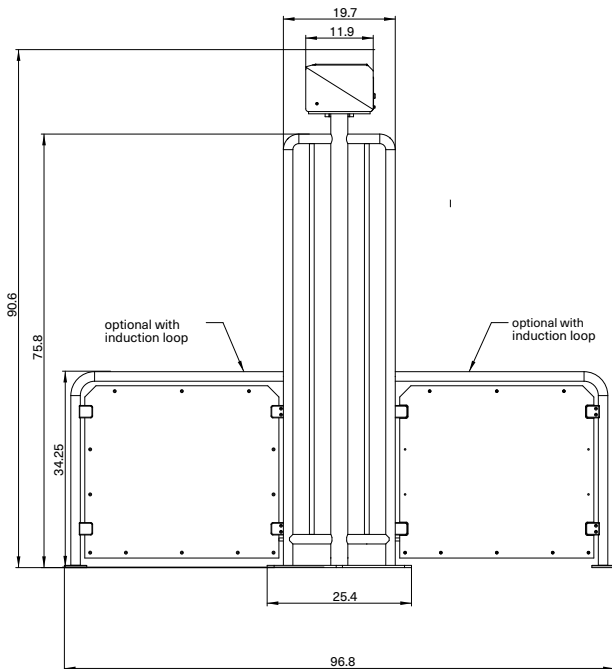

MPG 162
View from below

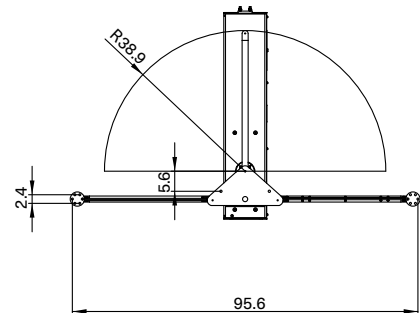

MPG 172
View from below

